

Contents

FREQUENTLY ASKED QUESTIONS	4
TRAILER INFORMATION	6
Awning	6
Battery Power (see also Power)	6
Bears	6
Black Water (Sewage or Toilet Water)	6
Checking Out.....	7
Critters	7
Dishes.....	7
Early Departures	7
Emergencies.....	7
Gas (Propane)	8
FOR YOUR SAFETY.....	8
Generator.....	8
Gray Water (Shower and Sink Water)	9
Heater (Furnace).....	9
Hot Water	9
Lights.....	10
Lost and Found	10
Messages	10
Phones	10
Power (see also Battery Power)	10
FOR YOUR SAFETY.....	11
Refrigerator.....	11
Reservations (760) 935-4890 ext. 1.....	11
Service Staff (760) 935-4890 ext. 2.....	11
Showers	11
Stove and Oven.....	12
IF YOU SMELL PROPANE GAS.....	12
Toilet	12
Water	12
Tips to conserve water:	13
Water Heater	13

AWNING INFORMATION AND DIRECTIONS.....	14
Important information regarding awning damage	14
Using the awning	14
Automatic Awning	14
Manual Awning.....	14
Opening the Manual Awning.....	15
Closing the Manual Awning.....	16
GENERATOR INFORMATION AND DIRECTIONS	17
Generator safety.....	17
Honda 2000 watt generator	18
Manual pull start.....	18
Honda 3000 watt generator	19
Manual pull start.....	19
Key start.....	19
IMPORTANT PHONE NUMBERS	20
Adventure in Camping (AIC) Phone Numbers	20
Emergency Services and Government Agencies	20
Mammoth Area Activities.....	21
Devils Postpile National Monument.....	21
Frosty's Miniature Golf	21
Hayden Cabin.....	21
Helicopter Tours SkyTime LLC.....	21
High Sierra Jeep Adventures.....	21
Mammoth Lakes Pack Outfit	21
Mammoth Mountain Bike Park	21
Mammoth Mountaineering Supply	21
Mammoth Rock 'n' Bowl – Bowling Alley.....	21
Mammoth Ski Museum	21
Snowcreek Athletic Club.....	21
Southern Mono Historical Society.....	22
Troutfitter	22
Whitmore Pool.....	22
XTC Tours	22
Mammoth Lakes Area Sporting Goods Locations	22

Alpine Approach 22

Command Performance-Fast Ski Sports 22

Footloose Sports 22

Freetime Ventures Inc 22

Kittredge Sports 22

Mammoth Sporting Goods 22

McCoy Sports 22

P-3 Sports 23

Rick's Sport Center 23

The Trout Fly 23

Wave Rave Snowboard Shop 23

Bishop Area Information..... 23

 Bishop Chamber of Commerce 23

 Reagan’s Sporting Goods..... 23

BRIEF HISTORY OF THE AREA 24

THINGS TO SEE AND DO 25

FAVORITE DAY HIKES 27

FREQUENTLY ASKED QUESTIONS

I have a question or need service during my stay. Who do I call?

We pride ourselves on customer service. We offer 24 hour customer care; however, we appreciate being able to service your trailer during our regular business hours, 8am to 5pm. Many questions can be answered over the phone. In some campgrounds service is limited but text messages seem to work. Regardless, if you need anything, please call us. (760) 935-4890

What time is check out and what do I do when leaving?

Your checkout time can be found on the front of your contract. When the time has arrived, please leave the keys (2) on the table and the door unlocked. Please clean the dishes and utensils, wipe down the counters, and sweep the floor. Please leave the awning closed. You are not required to wait for trailer pickup. Drive home safely, see you again soon!

I want to extend my stay, get something extra, or purchase firewood.

Great! We would love to have you stay longer. Often, we have your trailer available at a discounted price. Call (760) 935-4890 and we will be glad to help. We offer other extras including BBQ grills, shade canopies, camp mats, tables, chairs, lounge chairs, and generators to make your stay even better.

We just arrived and the black water shows other than empty on the monitor panel. Is it full?

We deliver every trailer with the fresh water tank FULL and holding tanks for gray water and sewer (black water) certified EMPTY. The monitor panel may sometimes show inaccurate readings due to debris on the sensors, however, we visually check to make sure the tanks are EMPTY and ready for use.

I want to use the awning but have not been instructed how to use it. What do I do now?

Please contact our service line (760) 935-4890 and we will schedule a driver to come to your campsite and show you the proper operation. Although the operation is simple, not following directions can cause damage or injury. If you have extended the awning and plan to be away from the trailer for more than a few minutes, please put the awning away before leaving. Winds may gust and damage the awning. When using the awning during your stay, you are financially responsible for damage to the awning or trailer caused by the awning.

Where is the mop, bucket, broom, dustpan, water hose, water jug & funnel?

These items are typically found in the outside of your trailer towards the front inside one of the compartments which are unlocked. In some models, these items are found in an inside cabinet or closet.

Why am I not getting any water from the faucets?

Check the water pump switch. Is the toggle switch in the ON position? There should be a red light on if the switch is turned to the on position and you should hear the pump cycle or run if a faucet is on. Once you are finished with the water or leaving for the day, please turn the pump switch off to conserve water and battery power.

Why don't I have hot water?

Check the water heater switch. Is the toggle switch in the ON position? When first turned on, an orange light may come on for only a few seconds. Please give water heater at least 30 to 40 minutes to heat the water. Once hot water is no longer needed, or if you are leaving for the day, please toggle switch to OFF position to conserve propane.

I rented a generator. What do I need to know?

The generator shall be kept locked to the trailer. It was filled with premium gas upon delivery. Please Note: The muffler becomes very hot during operation and remains hot for several minutes after stopping engine. Be careful not to touch the muffler while it is hot. When refueling, turn the generator off. Slowly pour the gas into the generator using caution not to spill. Keep away from cigarettes, sparks, and fire when refueling the generator. Keep children and pets away from generator while it is in operation.

TRAILER INFORMATION

Awning



The awning on your trailer is very delicate in the wind. A service representative needs to show you the proper method to open and close the awning. Please refer to the awning directions included in this book. If you are unsure how to use the awning properly, please contact a service representative for assistance.

Battery Power (see also Power)

Your trailer is equipped with a 12 volt battery system including a solar charging system installed on the roof. If you are dry camping (without 110v shore power in an RV park or generator), this is the only power system you have. If you are in an RV Park with 110v electric hook-up, the 12 volt battery is still required to complete the electrical circuit but is not necessarily used for power. Even with the solar system charging the batteries during the day, it is important to conserve your power. Your lights, the fan for the heater, and the water pump use the battery power. Just like your cell phone, excessive use will deplete the battery life. Leaving a light or the heater on while you are gone during the day will drain the battery quickly.

A fully charged battery system will be delivered with the trailer. This battery system should last your entire stay with proper conservation. If you find that you need a replacement battery, please make arrangements to have one delivered during our regular service hours (8am – 3pm). Excessive use of the battery system may result in an additional service charge.

Please DO NOT attempt to charge the batteries yourself. Doing so may damage the trailer's electrical system resulting in a charge to you.

Bears

You may see bears in your campground. They are generally more interested in your trash and food than you. As a precaution, do not leave trash or food around your campsite. Keep coolers locked inside the bear boxes provided at the campsites. Left-over food should be in an air tight bag or plastic container. There is generally information posted at the beginning of the campground regarding bears or you may ask the camphost or rangers if you have questions. Please do not feed the bears. It is dangerous and encourages them to return to your campsite.

Black Water (Sewage or Toilet Water)

The sewer system in the trailer is closed and will remain closed during your stay. With proper conservation, the sewer tank will not need to be emptied until the end of your stay. Over flushing the toilet or allowing too much water to run into the toilet will cause the tank to fill faster. Make sure when you finish flushing, the flush handle is returned to the closed position. Turning off the water pump when not in use will ensure there is no water pumping into the toilet. Adventure in Camping will empty the black water tank when the trailer is returned. Please leave the black outside lever in the closed position during your stay.

If you are staying in an RV park and properly fitted to the park's sewer system, you may empty the black water if needed during your stay. For proper draining, the dump valve should still remain in the closed position until it is required to be dumped. For questions, please contact our service staff.

Checking Out

On your last morning, please be aware of your check-out time. Check-out times are strictly enforced. Late check-outs will be charged \$50 per hour. Check to make sure you have all your belongings (don't forget the outside compartments and under the beds). We are not responsible for items left inside the trailer or at the campsite. If you are ready to check-out and the Driver has not arrived, you may leave the keys inside and leave the trailer unlocked.

When checking out: Please clean dishes, empty all trash, and empty the gray water container (blue or gray container located behind the trailer) if you requested one for your stay. If you did not request a gray water container, simply leave the valve closed and we will dispose of the waste water.

Critters

Squirrels, chipmunks, mice, bugs, lizards, raccoons, etc... All these creatures want to get into your trailer. It's warm and loaded with food. Please remember to keep food well wrapped (best in Ziploc bags or Tupperware type containers) and stored in the cabinets or in the refrigerator/cooler. Most campsites provide a "bear box" where you can store food items and coolers.

Remember to keep the trailer or screen door shut at all times, as this will help keep the bugs out. Do not leave food items in your vehicles; bears have been known to break in. It is also best to remove trash from the trailer on a regular basis as it attracts "critters" as well. Do not leave trash in your vehicles, the back of your truck, or outside; always dispose in the bear-proof waste dumpsters.

Dishes

For ease of use during your stay, we suggest using paper plates and utensils but welcome your use of the dishes provided. The best way to clean the dishes and conserve water is to fill one side of the sink with warm soapy water and the other with clean water. Wash the dishes in one side and rinse them in the other. Running water to wash and rinse will deplete your water supply and fill your holding tanks. Please wash the dishes prior to your check out.

Early Departures

If you are leaving prior to your scheduled departure day, please call give us a call at 760-935-4890 so we can arrange to pick up the trailer. Please leave the keys inside with the trailer unlocked.

Emergencies

For all medical, fire, and police emergencies, **Dial 9-1-1.**

For non-emergency assistance, most campgrounds have a camp host living on-site. If you are unable to use your cell phone to call for help and need assistance, you should attempt to contact the camp host for assistance. Generally, they will either have cell service or a land line phone and can call for assistance. There is a list of important phone numbers included in this book.

Gas (Propane)

The following appliances operate on propane gas: stove and oven, refrigerator, hot water heater, and heater. In most cases, the only pilot lights you need to be concerned with are the stove and oven pilots. The heater (furnace), water heater, and refrigerator are automatic and do not require manual ignition.

FOR YOUR SAFETY



If you smell gas: Check all pilot lights to make sure that they are properly lit. Re-light the unlit pilot lights. If all the pilot lights are lit and you smell gas, go outside or to a well-ventilated area and **CALL US**. We will send a Service Rep to your campsite immediately.

Generator

If you have a generator, it has been set up by service representative and locked to the bumper of your trailer. The generator was filled with gas (premium unleaded fuel only) and the oil level was checked prior to its delivery. It was also started and operated for a few minutes prior to delivery to ensure acceptable working order. There are specific instructions for the generator in this book.

When you use the generator, please follow these general guidelines to ensure proper operation:

1. The generator must be level.
2. Unplug the trailer from the generator.
3. Turn the ON-OFF switch to ON (This switch is located just under the rope pull; turning it counterclockwise ¼ turn will put it into the ON position).
4. Move the choke lever to the START position (Pushing it to the right).
5. NOTE: If the generator has been operating recently, DO NOT place this switch in the START position, as the generator will flood out.
6. Pull the starter rope quickly, but not too far out (Pulling the starter rope to the stop or all the way out will damage the starter). It may take 2-3 pulls to start the generator.
7. After the generator starts and runs for 20-30 seconds, move the choke switch to the left, or OFF.
8. Use the POWER SAVER switch to conserve gas.

NOTE: When re-filling with gas, turn the generator off. Slowly pour the gas into the generator, being careful not to spill. The gas can provided must be returned with the rental trailer. If you rented a generator, you were already charged for the fuel. There is no need to refill the can upon your departure.

If you experience any problems, please contact a service representative. DO NOT attempt to repair the generator yourself. You will be charged for damages.

If you own a generator and wish to connect it to the trailer's electrical power supply, please contact a service representative for assistance. We have adaptors available for rent or purchase. Installing the generator incorrectly can result in damage to the trailer's electrical system.

Gray Water (Shower and Sink Water)



While you are using the trailer, you will produce gray water. This is the shower and sink drain water. This water will collect in a holding tank(s) built into the trailer. The gray water tank is approximately 30-35 gallons. In the event the holding fills to capacity, the tub or shower will generally begin to fill with water. In this instance, you will need to arrange to have AIC empty the tanks. This service will be provided at an additional fee and during regular business hours and will be scheduled according to availability.

Please, do not dispose of gray water within the campground under any circumstances.

With proper conservation, the trailer's built in gray water holding tank is generally sufficient and you will not be required to dump the tank.

Heater (Furnace)

Your trailer is equipped with a gas furnace for heat. It is operated using a wall mounted thermostat. Although the heat is provided using propane gas, the fan for the heater runs off battery power. Excessive use of the heater will drain the battery. It is important to conserve.

To use the heater: Make sure the ON and OFF switch on the thermostat is in the proper position (if applicable). Set the thermostat to the desired temperature. To conserve, turn the heater down or off during the day and when you are not inside the trailer.

If you turn the heater on and do not get heat:

1. Make sure the ON and OFF switch is set correctly.
2. If the fan is working but only blowing cold air, the battery on the trailer may be getting low.
3. Please contact a service representative for assistance.

Hot Water

Your trailer is equipped with a hot water tank. This tank is small (approximately six gallons – yours at home is probably 40-50 gallons) and will not last long. Following the water conservation tips will help. You may need to wait 10-15 seconds while running the hot water before actually getting hot water to the faucet.

If you attempt to use hot water and it is cold:

1. Check to make sure the hot water heater is lit. If the wall switch light is on, the water heater has faulted and needs to be reset.
2. If the water heater is out, turn on the water heater switch and wait for proper ignition.
3. If the water heater is on, the light is not on, but the heater is not working; turn off the switch, wait for 10-15 seconds, and turn the switch back on.
4. You may hear a clicking sound; this is the automatic pilot trying to light. If the clicking sound stays on more than a minute or two and the heater does not ignite, please contact our service staff.
5. Please allow approximately 30-60 minutes from initial cycle for the water to be properly heated.

Remember to turn the hot water heater off when not in use. This will help conserve propane for your stay. The switch is located in the kitchen area and clearly labeled. During high winds, the heater may not stay lit and continually run through the lighting cycle. You may want to turn it off until high winds subside.

Lights

The lights in the trailer operate on battery power when dry camping. Just like your cell phone, leaving a light on continuously will drain the batteries. Before you leave the trailer for the day, make sure you have turned off all the lights. You may find some of the lights are operated by both a wall switch and a switch on the light itself.

Lost and Found

During your stay, please remember to lock up your belongings when leaving the trailer unattended. Adventure in Camping and its employees are not responsible for lost, stolen, or items left inside the trailer after your departure.

If items are found after your stay, Adventure in Camping is happy to arrange return of these items to you. Please understand you will be responsible for shipping and handling fees.

Messages

If you are expecting a message, please notify our office. We will generally not deliver messages to campsites; however, we will take them and relay them to you if you call our staff. If we receive an emergency message and do not hear from you, we will contact the Sheriff's Department and have them make determination as to whether they will deliver the message to your campsite. If we have a message for you or your party and are in the area where you are camping, we will make every effort to relay the message in person.

Phones

Some campgrounds have payphones in or around the area. Cell coverage may be hit or miss depending on your provider. With low cell service, you may still be able to text even if you cannot make calls. You should take a moment to determine if you have cell service or find the nearest payphone.

Power (see also Battery Power)

The following appliances operate on electrical (battery) power: Water pump, fan for heater, and lights.

If your trailer is parked in an RV park with electrical hookups:

The trailer is "plugged in" to shore power (110v household power). Use of electrical outlets and microwave is possible. Conservation of lights, pump, and heater is not necessary.

If you are "dry" camping without electrical power supply:

The trailer is operating on BATTERY power only. It is important for you to conserve. The electrical outlets and microwave will not work.

If your lights go dim or the heater stops working (blowing cold air only):
Your battery is going dead. Please call us between 7am-3pm to schedule battery replacement.



FOR YOUR SAFETY

DO NOT attempt to change or charge the batteries on your own. This will cause damage to the battery and trailer. DO NOT pull protective covers off or remove wiring. This may cause serious injury to you. If you experience problems with your power, please call us and we will send out a service representative.

Refrigerator

The refrigerator in the trailer should already be on when your trailer is set up. The refrigerator operates on gas power and is regulated automatically.

If you find that the refrigerator is not cold:

1. Check to see if the **CHECK** light is on.
2. If it is, turn the refrigerator off at the control panel, wait 15-30 seconds and then turn it back on.
3. You may hear a clicking sound.
4. The clicking sound should stop and the **CHECK** light should turn off. If the clicking sound stays on for more than a minute or two, or if the **CHECK** light stays on, call a service representative for assistance.

Please note, it may take 3-6 hours for the refrigerator to get cold. Opening the door repeatedly during this time will delay the refrigerator in getting cold. To see if the refrigerator is getting cold, check the freezer. The refrigerator drafts cold air from the freezer. If the freezer is getting cold, the refrigerator is working properly. The refrigerator does not work like one in your home. Leaving the door open for prolonged periods of time, even for a few minutes, will cause the refrigerator to lose its cold temperature and take time to go back to the desired temperature.

Reservations (760) 935-4890 ext. 1

If you wish to adjust your reservation, extend your stay, or add anything to your camping vacation, please call (760) 935-4890 ext. 1 for assistance.

Service Staff (760) 935-4890 ext. 2

Adventure in Camping prides itself on its service. Please call us if you have any questions during your stay regarding the trailer or the area. If you reach a voicemail, please leave a message as we will return your call. When leaving a message, please include your name, trailer number, campsite location, and a return phone number. Our service staff is generally only available daily from 8am-4pm. For emergencies, we do have an afterhour's answering service.

Showers

Taking a shower in an RV is quite different than taking a shower at home. The hot water heater in an RV is small (approximately six gallons). The best way to take a shower and have hot water the entire time is to first rinse yourself down, then turn the water off on the shower head by turning the dial,

lather up, and turn the water back on to rinse off. Then, turn the water off at the tub faucet. This will also help you conserve water.

Stove and Oven

The stove and oven in the trailer operate on propane gas. It is important to follow the safety guidelines when operating these appliances.

The oven operates on a pilot light. This pilot light should stay on throughout your stay. The oven dial should be positioned to “Pilot”. If you turn off the oven and turn it back to Pilot, you will need to relight the pilot light.

To relight the pilot light on the oven:

1. Turn the oven knob to “Pilot”
2. Press the knob in towards the oven
3. While holding the oven knob in, light the pilot mechanism located at the bottom rear of the oven burner assembly.
4. Continue holding the knob in and wait approximately five seconds while the blue pilot light is lit.
5. The pilot light should now stay lit after you release the knob.

If you do not wish to use the oven, you may turn the oven knob to “Off”.

The stove top may not have a pilot light. If equipped with a spark ignition, turn on the desired burner and turn or depress the spark ignition until lit. If you are unable to light with the spark ignition, you may need to light the burner with a match or lighter.

If you try to use the stove or oven and they do not operate: Make sure the pilot light is still on. If it is out, relight the pilot.



IF YOU SMELL PROPANE GAS

Make sure the pilot light on the oven is lit or off. If it is lit or off and you still smell gas—call a service representative for assistance.

Toilet

Please see BLACK WATER.

Water

You will use water for the kitchen and bathroom sinks, shower, and toilet.

If your trailer is parked in an RV Park or you have a water hookup:

The trailer will be hooked up directly to water. You should always try to conserve water but it is not as important. Please note, although you may be hooked up to water, unless you are hooked up to sewer, you will still be filling your holding tanks. For this reason, please conserve the use of the toilet.



If you are “dry” camping without direct water supply:

You will be using the trailer’s water tank. This is usually a 35-40 gallon tank. Conservation is very important! The trailer was delivered with the tank full. You are not required to refill the tank; however, if after the initial water is used you wish to refill the water, it is your responsibility to fill the tank at the campsite using the provided hose or water jug. The hose provided may not reach water spigots in campground and you may need to use the jug. Under no circumstances will the fresh water tank be filled with creek water, lake water, or any other non-potable liquid. Your safety and comfort are our primary concern. Please note the tank and fill receptacle is an open system capable of accepting any liquids introduced. Prior to your stay, AIC emptied and flushed the tank and used filtered and treated water to refill the tank; however, AIC cannot guarantee contaminants have never entered the water system nor can AIC guarantee the water in the tank is acceptable to drink. AIC routinely tests the water used to fill the fresh water tank for presence of contaminants; however, AIC strongly recommends using the fresh water tank only for bathing and using bottled water for drinking and cooking.

If the water pump runs constantly but you don’t get water from the faucet, you have run out of water. In this case, turn off the water pump to conserve battery power. Use the hose or water jug(s) provided in the storage compartment to refill the water tank. Fill the tank with potable drinking water only.

If you run the water pump continuously, a full water tank will run dry in about 15 minutes. Conservation is very important. You may want to buy drinking water and use the water in the tank for bathing, washing dishes, and bathroom use.

Tips to conserve water:

- Using campground restrooms during the day and reserving trailer restroom for night.
- Turning water off when soaping up or brushing teeth, only running water when rinsing.
- Take short showers by using the water saving switch/dial on the back of the shower head.
- Minimizing shower use by using wash cloths to bath rather than running water.
- Brush your teeth using a glass of water.
- Fill the kitchen sink to wash dishes rather than running the water continuously.
- Flush the toilet quickly.
- Fill a bowl or pitcher with used dish water to flush the solid waste in the toilet.
- Using water only to flush solid waste and leaving water off when flushing liquid waste.
- Turn off the water pump when not in use or when away from the trailer.
- Considering the use of paper plates and plastic utensils to reduce dishwashing.
- Using bottled water for drinking and cooking and only using trailer tank water for dishwashing, restrooms and bathing.

Water Heater

Please see HOT WATER.

AWNING INFORMATION AND DIRECTIONS

The awning on your trailer is very delicate in the wind. A service representative needs to show you the proper method to open and close the awning. Please refer to the awning directions included below. If you are unsure how to use the awning properly, please contact a service representative for assistance.



Important information regarding awning damage

To reduce the risk of injury to yourself and others and damage to the awning, please:

1. Do not leave the awning open while you are away from the trailer.
2. Do not leave awning open if it is windy, even in a light wind.
3. Always leave the base supports of the awning attached to the trailer.
4. Do not hang anything from the awning or allow children to hang on the supports.
5. Do not tie animals to the supports or awning arms.

Damage to the awning will result in a charge including replacement parts and or fabric and loss of rental revenue to due to down time of trailer during repair.

Using the awning

Automatic Awning

If your trailer is equipped with an automatic awning, you simply open and close the awning using the button inside the trailer.



IMPORTANT

Before extending or retracting the awning, make sure the black knobs are loose.

Manual Awning

If your trailer is equipped with a manual awning, please follow the instructions on the following pages. For ease of use, we recommend two people open and close the awning. If you have any questions or concerns regarding the awning, please contact a service representative.

Opening the Manual Awning

1. Loosen the adjustment lock knob and travel lock located on each main arm. (Fig. 1)
2. Locate the Safe-T-Lock lever on the right end cap of the fabric tube roller (top right end). Either by hand or using the hook of the pull rod provided, pull the lever forward into the "ROLL DOWN" position. (Fig 2.)
3. Either by hand or using the hook of the pull rod provided, pull the awning strap outward and completely extend. The awning should stay positioned in the extended position by itself. In the event there is no pull strap, you may extend by gently pulling out on each of the main arms. (Fig. 3)
4. From the side of either arm assembly, slide the rafter arm up the support arm until it locks into place over the slider catch located at the top of each arm. Gently place downward force on the main support arm to remove slack from the fabric and tighten the black adjustment knob on the rafter arm. Repeat this step for the other side. (Fig. 4)
5. Reposition the pull strap out of the way and secure it to one of the arm assemblies. Please do not use the strap to hang on or tie to items such as animals. Doing so may cause damage to the awning. (Fig. 5)
6. Raise awning arms by pulling lift handle and lift the arm assembly. Awning should be raised high enough so the door will clear the fabric but not over extended. When at desired height, release handle and snap into pre-punched hole in arm. Repeat for the other side. (Fig. 6)

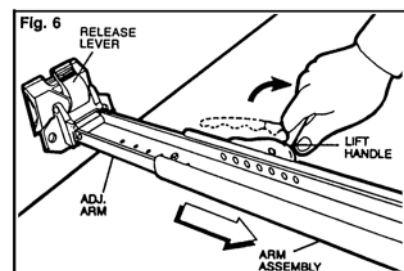
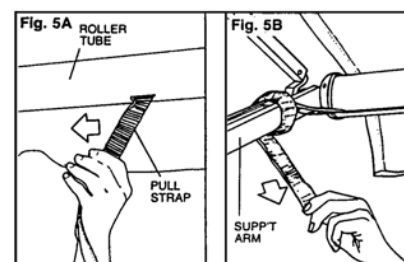
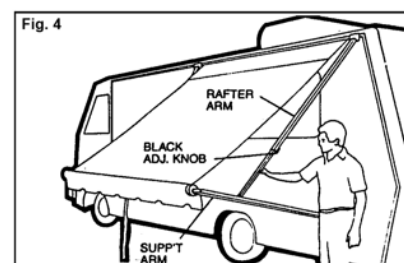
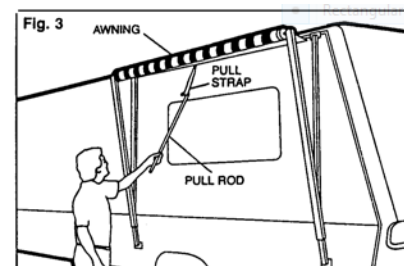
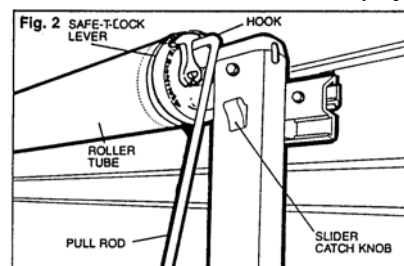
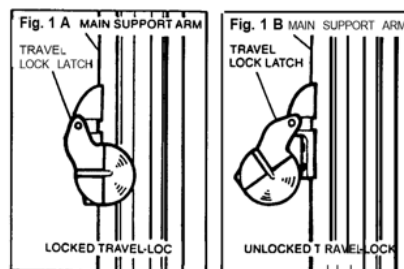

AWNING CAUTION

The awning arms should remain attached to the trailer at all times. Removing the arm and using the "patio feature" makes the awning unstable in winds and can cause serious injury and or damage to the awning and the trailer.

You are responsible for the safe operation of the awning. If you need assistance to properly operate the awning or have any questions, please call a service representative.

Closing the Manual Awning

1. Raise the lift handle on the arm assembly and release the lock button. Lower the main support arm down to the base of the arm. The lift handle should lock into a pre-punched hole at the base of the arm. Repeat for the other side.

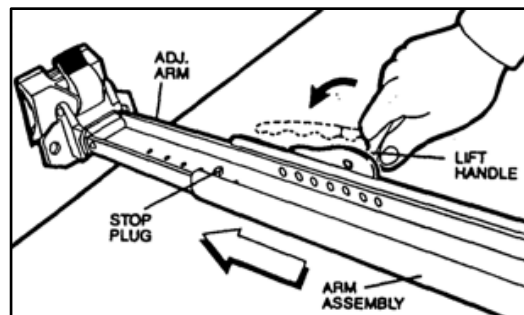

2. Loosen black adjustment knob on the rafter arm and lift on the slider catch located at the top front of the main support arm. Slide the rafter arm down to the bottom of the main arm. DO NOT retighten the black knob.

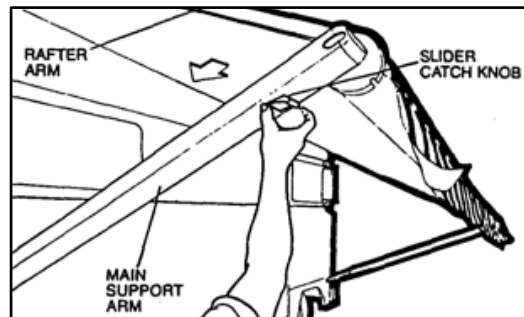

3. Prepare the fabric roller tube assembly for roll up. Pull down on the pull strap or support each arm. Flip the Safe-T-Lock switch lever to the ROLL UP position.

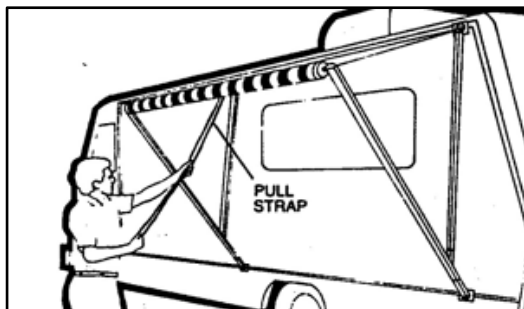

CLOSING CAUTION

DO NOT release the awning once you have moved the Safe-T-Lock switch to the ROLL UP position as the awning is now under tension and will snap back against the vehicle and cause injury or damage. Keep tension on the awning and gently allow it to roll up.

GENERATOR INFORMATION AND DIRECTIONS

Generator safety



For your safety, please follow all directions provided with the generator and in this book.

The muffler on the generator becomes **very hot** during operation and remains hot up to an hour or more after stopping engine. Be careful not to touch the muffler while it is hot as it will cause burns.

When refueling with gas (premium unleaded fuel only), turn the generator off. Slowly pour the gas into the generator using caution not to spill. Keep away from cigarettes, sparks, and open flames when refueling the generator. Keep children and pets away from generator while it is in operation.

If you experience any problems, call a service representative for assistance. Please **DO NOT** attempt to repair the generator in any way. You could be held responsible for any damages to the generator or trailer.

Honda 2000 watt generator



Please refer to Generator Safety prior to operation.

Your generator rental has been delivered and set up by your Adventure in Camping representative and locked to the bumper of your trailer using an anti-theft lock. The generator was filled with gas (premium unleaded gas only please) and the oil level was checked prior to its delivery. For your convenience, you have also been provided an extra full gas can for re-filling the generator. The generator was also started and operated for a few minutes prior to delivery to insure it is in acceptable working order.

When you use the generator next, please take the following steps to insure proper operation:

1. Make sure the A/C is "OFF" in the trailer.
2. The generator must be level.
3. Due to high altitude, loosen the gas cap so that it only rests on the tank hole.
4. On the generator, turn the "ON/OFF" SWITCH TO "ON" position. (This switch is located just under the rope pull)
5. Move the choke lever (Pushing it to the right) to the "START" position.
6. Make sure the "Eco Throttle" switch is pushed to the right towards the "OFF".

Manual pull start

1. Pull the starter grip lightly until resistance is felt, then pull briskly out. Repeat if necessary.
2. After the generator starts and runs for 20-30 seconds, move the choke switch back to the left or "OFF" position.
3. To turn generator OFF, turn the "ON/OFF switch to the "OFF" position. (Located just under the rope pull)

After the generator has been running for about 60 seconds, use the "Eco Throttle" switch to conserve gas by pushing it to the left in the "ON" position.

Honda 3000 watt generator



Please refer to Generator Safety prior to operation.

Your generator rental has been delivered and set up by your Adventure in Camping representative and locked to the bumper of your trailer using an anti-theft lock. The generator was filled with gas (premium unleaded gas only please) and the oil level was checked prior to its delivery. For your convenience, you have also been provided an extra full gas can for re-filling the generator. The generator was also started and operated for a few minutes prior to delivery to insure it is in acceptable working order.

When you use the generator next, please take the following steps to insure proper operation:

1. Make sure the air conditioner is "OFF" in the trailer.
2. The generator must be level.
3. On the generator, turn the "ON/OFF" switch to "ON" position. (This switch is YELLOW and located just to the right of the panel. If done correctly, the switch should now be pointing up and down.
4. Make sure the "ECONOMIC" switch is pushed to the right towards the "O".

Manual pull start

1. Make sure the "REMOTE" switch is pushed to the right towards the "O".
2. Turn the key clockwise to the "ON" position.
3. Pull the starter grip lightly until resistance is felt, then pull out briskly. Repeat if necessary.
4. To turn generator OFF, turn the key to the "OFF" position.

Key start

1. Turn the key clockwise to "START" position and hold for a few seconds until the generator starts.
2. If the generator does not start within a few seconds, move the choke lever (pulling it out) while holding the key in the "START" position. As soon as the generator starts, push in the choke lever and allow the key to return to "ON" position.
3. To turn generator OFF, turn the key to the "OFF" position.

After the generator has been running for about 60 seconds, use the "ECONOMIC" switch to conserve fuel by pushing it to the left in the "I" position.

IMPORTANT PHONE NUMBERS

All phone numbers and addresses are deemed reliable at the time of publishing. Adventure in Camping accepts no responsibility for wrong numbers, disconnected lines, or companies that are now out of business or closed for the season.

Adventure in Camping (AIC) Phone Numbers

AIC Main Office and Reservations	(760) 935-4890 ext. 1
AIC Service Office and Staff	(760) 935-4890 ext. 2
AIC Fax	(760) 935-4896
AIC Email	reservations@adventureincamping.com

When leaving a message, please include your name, campground name and space number, and trailer number you are staying in.

Emergency Services and Government Agencies

Emergencies (Medical, Fire, Police) 9-1-1

Police Department	
Mammoth Lakes	(760) 965-3700
Bishop	(760) 873-5866
Sheriff Department	
Mono County	(760) 932-7549
Inyo County	(760) 878-0383
Hospital	
Mammoth Lakes	(760) 934-3311
Bishop	(760) 873-5811
Forest Service Ranger Station	
Lee Vining	(760) 647-3044
Mammoth Lakes	(760) 924-5500
Road Information	(800) 427-7623

Mammoth Area Activities

Devils Postpile National Monument S.R. 203 Mammoth Lakes, CA 93546	(760) 934-2289
Frosty's Miniature Golf 164 Old Mammoth Rd Mammoth Lakes, CA 93546	(760) 934-2515
Hayden Cabin 5489 Sherwin Creek Rd Mammoth Lakes, CA 93546	(760) 934-6918
Helicopter Tours SkyTime LLC. Mammoth Lakes Airport Mammoth Lakes, CA 93546	(321) 247-8687
High Sierra Jeep Adventures Highway 158 June Lake, CA 93529	(949) 294-6588
Mammoth Lakes Pack Outfit 2344 Lake Mary Rd Mammoth Lakes, CA 93546	(760) 934-2434
Mammoth Mountain Bike Park 1 Minaret Rd Mammoth Lakes, CA 93546	800-626-6684
Mammoth Mountaineering Supply 361 Old Mammoth Road Mammoth Lakes, CA 93546	(760) 934-4191
Mammoth Rock 'n' Bowl – Bowling Alley 3029 Chateau Road Mammoth Lakes, CA 93546	(760) 934-4200
Mammoth Ski Museum 100 College Pkwy Mammoth Lakes, CA 93546	(760) 934-3781
Snowcreek Athletic Club 51 Club Drive Mammoth Lakes California 93546	(760) 934-8511

Southern Mono Historical Society (760) 934-6918
 5489 Sherwn Crk Rd
 Mammoth Lakes, CA 93546

Troutfitter (760) 924-3676
 2987 Main St
 Mammoth Lakes, CA 93546

Whitmore Pool (760) 965 3697
 904 Benton Crossing Road (Green Church)
 Approximately one mile from Hwy. 395.

XTC Tours (760) 924-8480
 452 Old Mammoth Rd
 Mammoth Lakes, CA 93546

Mammoth Lakes Area Sporting Goods Locations

Alpine Approach (760) 934-6373
 6201 Minaret Rd,
 Mammoth Lakes, CA 93546

Command Performance-Fast Ski Sports (760) 934-4447
 437 Old Mammoth Rd,
 Mammoth Lakes, CA 93546

Footloose Sports (760) 934-2400
 3043 Main St
 Mammoth Lakes, CA 93546

Freetime Ventures Inc (760) 934-2471
 Mammoth Lakes, CA 93546

Kittredge Sports (760) 934-7566
 3218 Main St,
 Mammoth Lakes, CA 93546

Mammoth Sporting Goods (760) 934-3239
 425 Old Mammoth Road
 Mammoth Lakes, CA 93546

McCoy Sports (760) 924-7070
 80 Canyon Blvd,
 Mammoth Lakes, CA 93546

P-3 Sports (760) 934-9500
3325 Main St,
Mammoth Lakes, CA 93546

Rick's Sport Center (760) 934-3416
3241 Main St,
Mammoth Lakes, CA 93546

The Trout Fly (760) 934-2517
2987 Main St,
Mammoth Lakes, CA 93546

Wave Rave Snowboard Shop (760) 934-2471
3203 Main St,
Mammoth Lakes, CA 93546

Bishop Area Information

Bishop Chamber of Commerce (760) 873-8405
690 N. Main Street
Bishop, CA 93514

Reagan's Sporting Goods (760) 872-3000
963 N Main St
Bishop, CA 93514

BRIEF HISTORY OF THE AREA

In addition to the Native Americans who have inhabited the area for thousands of years, the area was first visited by white men searching for gold and silver in the mid 1850's, following the discovery of the Comstock Lode near Carson City, Nevada. Tales about a "Lost Cement Mine," which are still heard today, brought miners to the Mammoth Lakes area around 1877, and they began mining near Lake Mary. Within a couple of years, three small towns had sprung up around Lake Mary (originally called Summit Lake), with a population exceeding 1500. Three newspapers were circulated weekly to the four major mines. Mammoth Lakes was linked to the other mining areas of Bodie and Carson City by a weekly stagecoach, and by 1881, the gold had mostly tapped out and heavy winters moved most of the people to other lower elevation areas.

Evidence of early mining can still be seen on Old Mammoth Road, the Wildasinn Log Cabin and water wheel, along with the Mill site at the top of Old Mammoth Road where it meets Lake Mary Road.

The June Lake Loop was first surveyed in 1886 and has been a favorite fishing area ever since. Originally called "Horseshoe Canyon," it was accessed from the original HWY 23 (US 395) from the north junction via Rush Creek drainage (Grant Lake was not yet built), and ended at Goose Lake, now called Silver Lake. Carson Camp (now Silver Lake Resort) became the first development in the Loop. By 1924, the south road of the Loop was built along June Lake, and the Boulder Lodge and Heidelberg Resort were built in 1926. The fish hatchery was built at this time, supplying the local lakes with trout, and within a few years, the community grew, offering a hideaway for famous movie stars like Greta Garbo, Clark Gable, Wallace Berry, and Frank Capra. Most of the stars flew into the area by landing on a short dirt strip just east of June Lake. The year 1935 saw the construction of the Grant Lake dam, forming what is now Grant Lake, a reservoir for water sent to Los Angeles. By 1938, several rope tow "ski lifts" had been put into place and operated for years.

Along with the construction of Grant Lake dam, the aqueduct project linking the Mono Basin water drainage to the Owen's Valley River had begun. The towns of West Portal and East Portal sprang up to service the 5,000 workers needed for this 11 mile tunnel, which is dug under the Mono Craters, allowing the water to eventually flow to Los Angeles. Once the tunnel was completed, the buildings from these towns were moved to the nearby towns of Lee Vining, June Lake, and Mammoth.

Lee Vining started as a summer cattle farming area in the 1890's near the Tioga Lodge and later became a town in 1926. Many of the town's people were descendants of the miners working the mines of Lundy Canyon, Tioga Pass, and Bodie. By the 1950's, tours of Negit Island on Mono Lake were offered with overnight stays at the health ranch, which had mineral springs and mud baths for the more affluent travelers.

The new road into what is now the main street of Mammoth Lakes was built in 1937, and by 1941, Dave McCoy had moved his rope tow from McGee Creek to Mammoth Mountain. The rest is history...

THINGS TO SEE AND DO



Some of our favorite places to drive may require 4-wheel-drive. Please pay attention to posted signs. Be careful driving, and avoid soft sand, washed out areas, and rocks. Always go prepared, and don't forget snacks and water in case you need to hike out.

Visit the Deadman burial site across from the Cal Trans station at Crestview, half-way between June Lake and Mammoth. Crestview was named for the lodge that was located directly across Hwy 395 from the Cal Trans Station and was burned down in 1977. Drive to the west on the dirt road towards the Glass Creek campground, take the first available dirt road to the right, and drive to the end of this flat area, adjacent to Hwy 395 (a fenced tree marks the spot). See the beauty of this often overlooked camping area and take a short hike to the avalanche area, located at the end of the road. Park and walk a few hundred yards up the old logging path to see firsthand what effect an avalanche had on surrounding trees. We park trailers along this creek and road.

See West Portal, where the aqueduct starts. Listen to the river running under the metal inspection tube. This is also where a boat is lowered into the tunnel once a year to clean out any debris through the tunnel. Pumice and black obsidian rock can be found nearby, but be careful: the roads are made of sand, and getting stuck can easily happen.

Try to find East Portal, the last town site used for the construction of the aqueduct and a great place to hunt for antiques. Take the Big Springs campground road and follow the signs to Clark Canyon. A short distance from this area is where the aqueduct empties into, and starts, the Owens River.

Explore the Log Cabin mine, accessed by the road across from the Lee Vining Ranger Station. You can drive through the Berger's Retreat on the way, a beautiful private land hold where all sorts of wild animals feel comfortable lounging around. This road will take you up to the 10,000 foot level where you can walk through an old deserted gold grinding mill.

Don't miss Bodie, now a historical ghost town and state park, with hundreds of buildings in "arrested decay." On the drive from the Hawthorne road, you can see petroglyphs by following the road along the hillside leading into the canyon. The canyon road is also the site of the railroad tracks used to haul lumber from the other side of Mono Lake and used to build the town and shore up to the mine shafts. Make sure you pack a lunch and take plenty of water for this all-day outing.

View the entire San Joaquin River from the Minaret Summit lookout, just past the Mammoth Mountain Ski Area parking lot. Or park at Mammoth Mountain and take the hourly bus down to Devil's Postpile, Red's Meadow Pack Station, and the Rainbow Falls trailhead. The wild flowers in this area are the most beautiful in the Sierras, and you will most likely see deer in this area at any time of the day.

Drive to Mono Mills, the site of the wood mill and lumber yard used to build the town of Bodie and the mine shafts. This is one of the stops for the railroad, which was used to transport the lumber around Mono Lake. Several miles before this stop, you can take the road down to Mono Lake and

visit the shoreline and tufa towers. The water was believed to have mystic healing powers by the Native Americans and it's great for getting rid of fleas on your dog!

If you want to stay in Mammoth, take the short walk to the Log Cabin near the Stove restaurant. Walk to Mammoth Creek, turn left, and follow the creek for a few hundred yards until you see the footbridge. Daily tours of this cabin are offered in the summer. Or visit the Valentine Reserve, located up Old Mammoth Road, to see a beautifully maintained private reserve on the Mammoth Creek. Tours are also offered here.

If you're hot and need to cool off, find the rope swing on Gull Lake. Park at the entrance to Gull Lake Campground and hike around the lake to the west (left) a few hundred yards. This spot is great fun for the kids and has been enjoyed by the locals for many years. June Lake Beach is also a great place to swim and sunbathe; it is the only beach in the area and safe for kids. Even during the hottest periods of July and August, the water is always brisk!

Take the trail along Silver Lake, overlooking the site of Wallace Berry's cabin, destroyed by an avalanche. This is located halfway around Silver Lake at the wide spot in the road where there is ample parking and restrooms. This is also a favorite fishing area for the big trout and the prettiest place in the Sierra's during the fall colors. You can also see the original fish hatchery: located halfway up Fish Hatchery Hill, just past the Whispering Pines Motel. This is also the parking spot for the Fern Lake and Yost Creek trailheads.

Yosemite and Tuolumne Meadows are always a must for any visitor. You can have lunch in Tuolumne Meadows in the canvas tents. Deer are often walking and grazing in the nearby meadow in the morning.

Mammoth Mountain offers gondola rides to the top of the mountain: 11,053 feet! From here, you can almost see Fresno and have a superb 360° view of the Sierras. On your way up to Mammoth Mountain, stop off and see the earthquake fault.

Bike ride up Rock Creek Canyon and stop at the Rock Creek Resort for their daily homemade pies (these are famous throughout the area and go quickly). You can also drive and take in all the great fishing spots along the way. The fall colors in this canyon are breathtaking.

If you would like to hunt for ancient Native American arrowheads, they are often found on the back side of Crowley Lake. Take the Benton Crossing Road of Hwy 395, where the small green church is located (south of the airport); drive all the way around the lake and then stop at the dirt road on your left (about 4 miles past Layton Springs Road). Hike anywhere in this area and see old mine shafts and evidence of Indian summer camps. On your way back, take a dip at the Whitmore Hot Springs swimming pool, open to the public (fee required).

FAVORITE DAY HIKES

Parker Lake and/or Walker Lake:

On the June Lake Loop road, ½ mile in from the north junction with Hwy 395. Both lakes are exceptional fishing spots. Parker is easier and a little longer; Walker is more difficult but shorter.

Agnew, Gem, and Waugh Lakes:

Located in this order from the Silver Lake Resort, this hike is difficult, but has great views and excellent back-country fishing. Agnew is 2.5 miles; Gem one mile further, and Waugh is 2 miles past Gem, mostly uphill.

Agnew Meadows Trailhead:

Halfway down the Devil's Postpile road and accessible by bus, this trail leads to Shadow Lake, Garnet Lake, and Thousand Island Lake, in the order listed. This hike is mostly uphill and gets more difficult past Shadow Lake.

Duck Lake Trailhead:

This easy hike takes you to Arrowhead Lake and the Skeleton Lake. Much further past these lakes is Duck Pass and Duck Lake, a good day's hike.

The Sherwin Lake Trailhead:

Located off Old Mammoth Road, this trail is just past the creek and through the Sierra Meadow's Pack Station. Travel two miles towards the Sherwin Creek campground and park near the old motocross track site (clearly marked). This trail provides an easy hike and good fishing.

The Mammoth Creek Trail:

Starting at Old Mammoth Road, this trail offers great fishing and views of the petroglyphs found along the trail. As the trail is also paved, this is a great place to bike.

Fern Lake and Yost Creek:

This trail can be found halfway up the Fish Hatchery hill on the June Lake Loop road near the Whispering Pines Motel. This hike is strenuous but short.

The Trail to Bennetville Town:

This great day hike takes you to a historic site, and the trailhead is near Tioga Pass, halfway between Tioga Lake and Ellery Lake.